

ecoHITCH -Designed Specifically For Your **Green Vehicle**

Installation Instructions

Application Fits
2015+ Subaru Legacy
X7271 & X7272

2" & 1.25" EcoHitch Stealth

2,000 lbs Weight Carrying/200 lbs Tongue Weight

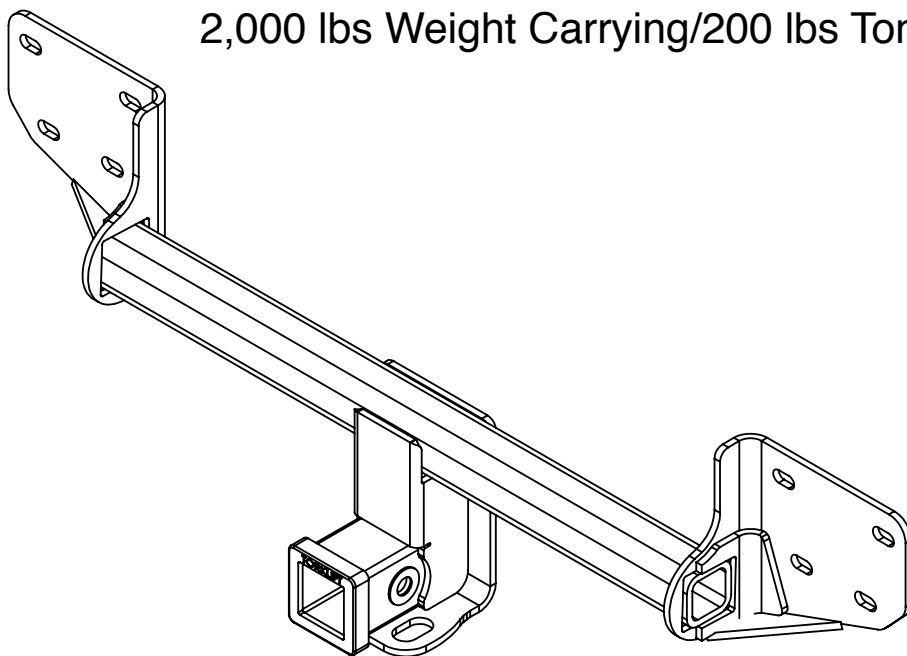

Torklift Central
315 Central Ave N
Kent, WA 98032
253-854-1832
www.torkliftcentral.com
support@tlcentral.com

Stay Connected



torkliftcentral



torkliftcentral



tlcentral



torklift central



torklift central



Bolt Kit Weight: 111g +/-

Hardware Included

QTY Fastener

8 M10-1.25 Serrated Flange Nut

1 18" Trim Lock Strip

READ THESE INSTRUCTIONS THOROUGHLY AND ACCOUNT FOR ALL HARDWARE LISTED BEFORE BEGINNING INSTALLATION!

Step 1. Raise vehicle on suitable jack stands, ramps, or hoist.

Step 2. Remove (3) screws and (2) push pins to remove mud guards in wheel wells. See Figure [1].

Step 3. Remove push button clips in the top rear of the wheel well by pressing into the center of the clip to release. Once the button is pushed in, you can pull the clip out. See Figure [2].



Fig [1]



Fig [2]

Step 4. Remove push pins (7 total) along the underside of the bumper fascia with a flathead screwdriver or other flat tool by releasing center of pin then pulling the whole pin out. Do not discard push pin clips. See Figures [3] and [4].



Fig [3]

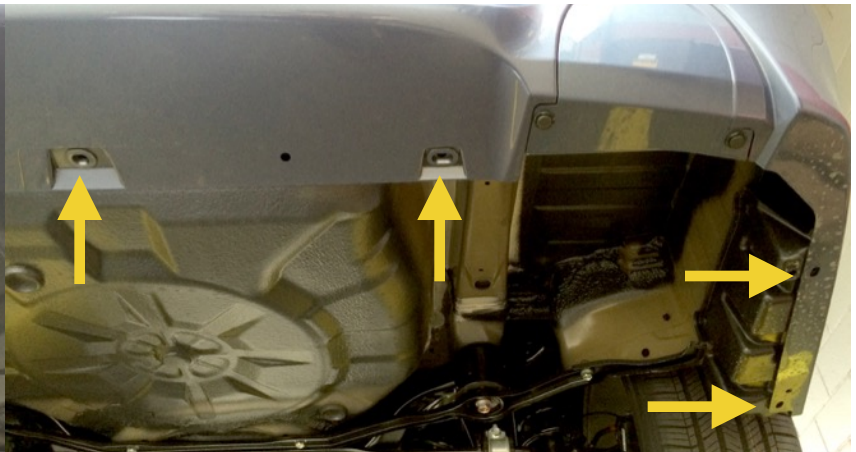

Fig [4]

Step 5. Open trunk lid. On the rear walls of the driver and passenger side you will notice a cargo net hanger. Remove these by turning 90 degrees and pulling outward. See Figure [5].



Fig [5]

Step 6. Peel back the fabric wall cover, remove plastic wire hangers, and disconnect light assembly wiring. See Figure [6].

Step 7. Remove the (6) nuts that secure the light assemblies to the vehicle on the driver and passenger sides. Once nuts have been removed, gently pull light assembly rearward to remove. See Figure [6].

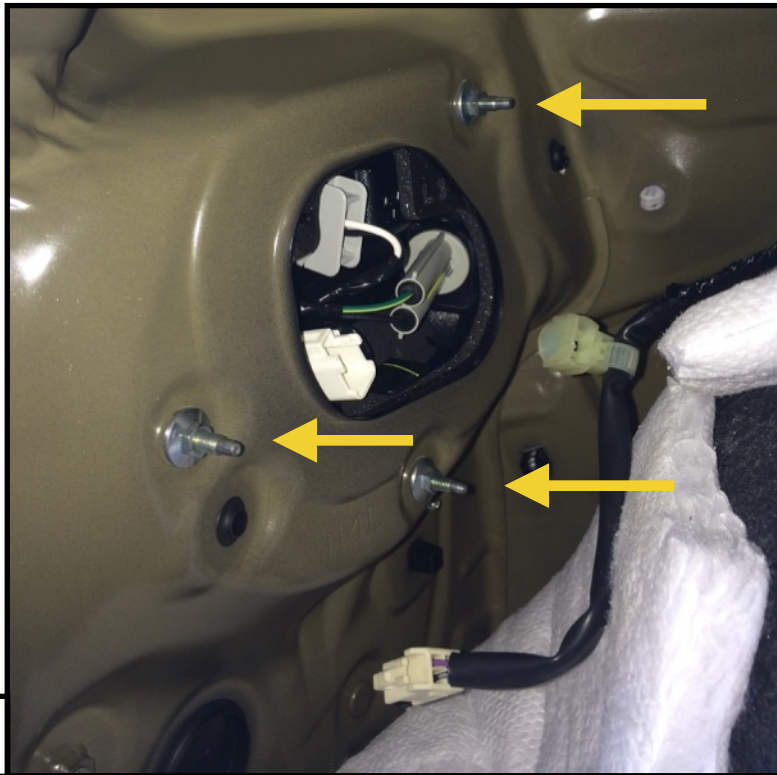

Fig [6]

Step 8. With the trunk lid lifted, pop off two screw covers and remove screws. See Figure [7].

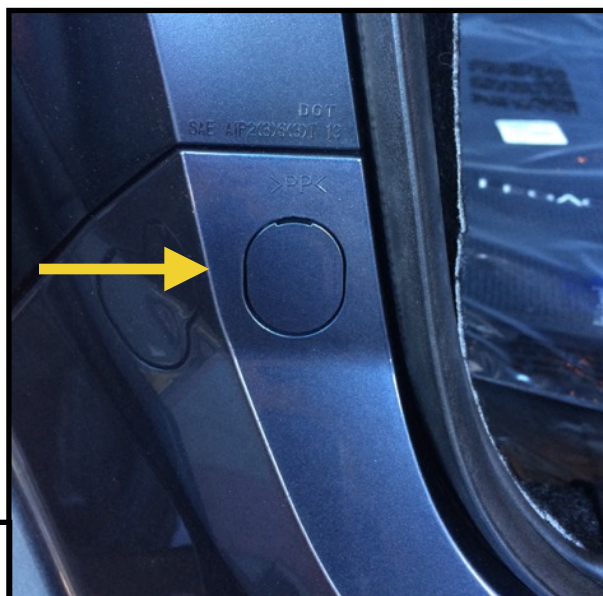

Fig [7]

Step 9. Starting on the passenger side, gently start to peel the bumper fascia outward working your way toward the back of the vehicle. When you reach the light assembly area, it may be helpful to use a pry tool to release the plastic tabs to prevent damaging these clips. Continue working your way around to the driver side until bumper fascia is removed. See Figures [8] and [9]. Remove styrofoam bar seen in Figure [10].



Fig [8]



Fig [9]



Fig [10]

Step 10. Remove (8) nuts holding impact bar to vehicle and discard. Remove impact bar and set aside. See Figure [11].

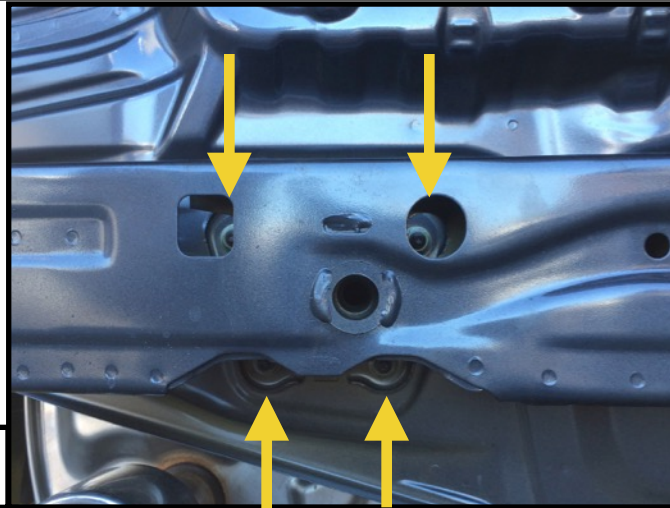

Fig [11]

Step 11. Bend center push pin tab upward to make way for hitch installation. See Figure [12].

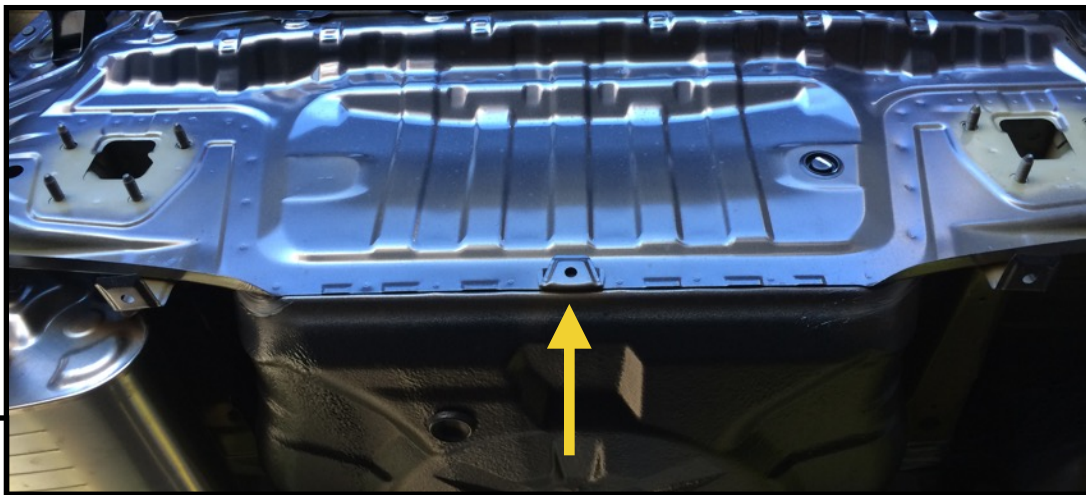

Fig [12]

Step 12. Place the EcoHitch on the eight welded studs of the vehicle. Replace the impact bar over the hitch and secure with the supplied M10x1.25 serrated flange nuts. Torque nuts to 48 ft-lbs. See Figures [13] and [14].



Fig [13]



Fig [14]

Step 13. Mark a 4-3/4" x 5-1/2" square at the center of the bumper fascia for trimming. Using an air saw or utility blade, trim out plastic and line with the supplied Trim Lock. Cut excess Trim Lock to fit. See Figure [15].

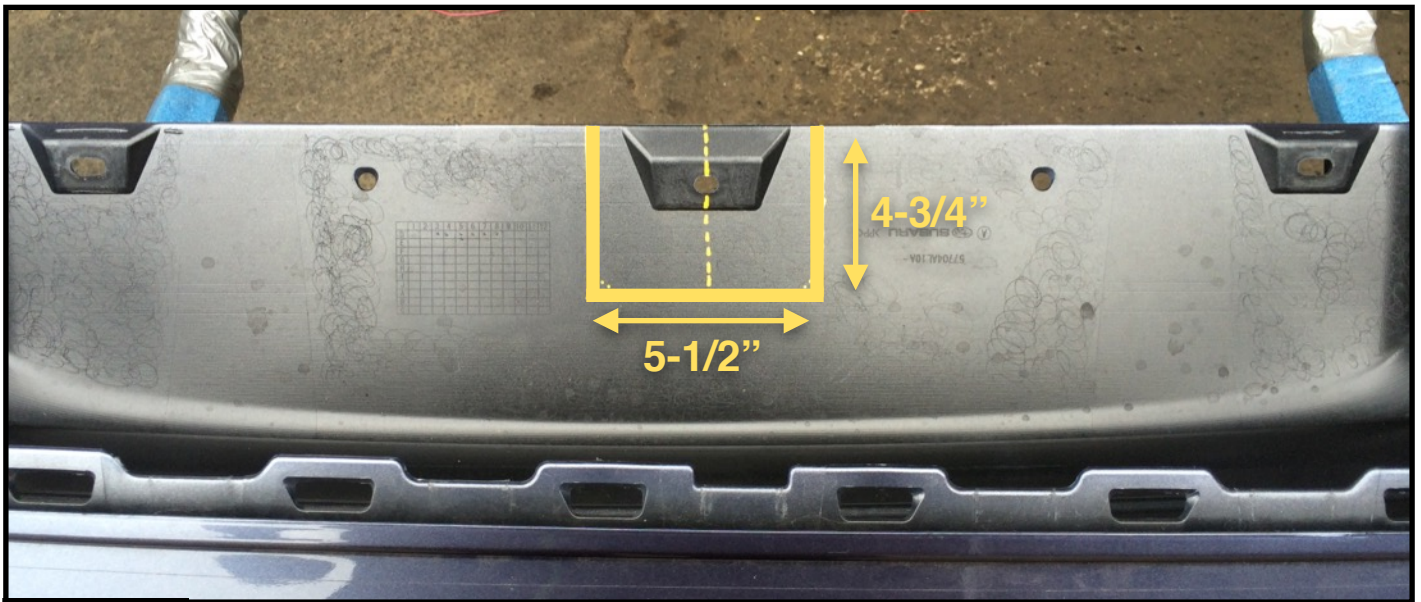

Fig [15]

Step 14. Replace styrofoam bar onto impact bar and reinstall bumper fascia and light assemblies by following steps in reverse from Step 8.

Congratulations on the completed installation of the Subaru Legacy Stealth EcoHitch! It is designed with a lifetime warranty for a lifetime of enjoyment. If you have any questions or suggestions please contact our tech support at support@tlcentral.com or by phone at (253)-854-1832.

WARRANTY/DISCLAIMER INFORMATION

Torklift Central requires proof of purchase for warranty claim registration, with pictures of any defective product before issuing a replacement. Torklift will not accept claims on any product without proof of purchase, which can be faxed, scanned, emailed or mailed to the information provided below. Torklift Central warrants its hitches, custom hitch receivers and accessories (excluding electrical wire harnesses which carry a warranty from their specified manufacturer) from date of purchase against defects in material and workmanship under normal use and service for the ownership life of the original consumer purchaser. Torklift Central will replace free of charge any part that proves defective in material or workmanship when presented to Torklift Central, transportation charges prepaid by purchaser, at the address below. **This warranty is limited to defective parts replacement only. Labor charges and/or damage incurred in installation or replacement, as well as incidental and consequential damages connected therewith are excluded.** This warranty does not include normal wear and tear or the finish and paint. Rusting, cracking or peeling of the finish is also excluded. Some states do not allow the exclusion or limitation of incidental or consequential damages, so the above limitation or exclusion may not apply to you. Any damage to Torklift Central products as a result of misuse, abuse, neglect, accident, improper installation or any use violative of instructions furnished by Torklift Central will void the warranty. This warranty gives you specific legal rights and you may also have rights, which vary from state to state. With warranty service, you may be able to go to a small claims court, a state court or a federal district court.

Although Torklift Central trailer hitches are both tested and rated for towing within the specific capacity label found on each trailer hitch. Torklift Central assumes no liability for vehicle manufacturers warranty due to the use of a Torklift Central trailer hitch being used for towing behind any vehicle or using the trailer hitch in a manner that it was not designed for. Although this specific trailer hitch has a load rating, which includes trailer tongue weight, and a trailer weight carrying capacity, Torklift Central is not responsible for the voiding of any warranty on any vehicle due to factory towing limitations. All vehicle warranties are the sole property and responsibility of the owner of the vehicle that the Torklift Central trailer hitch is installed upon. Torklift Central does not endorse towing behind any vehicle if the vehicles manufacturer states that towing is not recommended. Check your vehicle's owner's manual for the proper tow rating of your vehicle.

ADDRESS: 315 Central Ave N. Kent, WA 98032

WARNING Your vehicle may have a lower tow rating than this trailer hitch. If your vehicle's tow rating is less than the rated towing capacity on your Torklift Central trailer hitch, your trailer hitch capacity is limited to your vehicle's factory rated towing capacity.

FOR EXAMPLE: the label on your Torklift Central trailer hitch states it's capacity is rated for 500 pounds tongue weight and 5,000 pounds towing weight. However your vehicle's factory rated towing capacity is limited to only 350 pounds tongue weight and 3,500 pounds towing weight. In this example your maximum towing capacity of your Torklift Central trailer hitch is limited to 350 pounds tongue weight and 3,500 pounds towing weight as stated by your vehicle's maximum factory tow rating.

DANGER Never exceed your vehicle's manufacturer's recommended towing capacity which may be a lower rating than this trailer hitch

Unsure of your tow rating? Download our towing app from the app store to find your vehicles tow rating.
www.torkliftcentral.com/app.php